



Punzón cabeza cilíndrica
con aguja expulsora

**Tipo EKP, EKF,
EKO, EKR y EKS**

Forma de pedido:

Tipo HWS/ a x b x d₃ x L

Tipo HSS/ a x b x d₃ x L

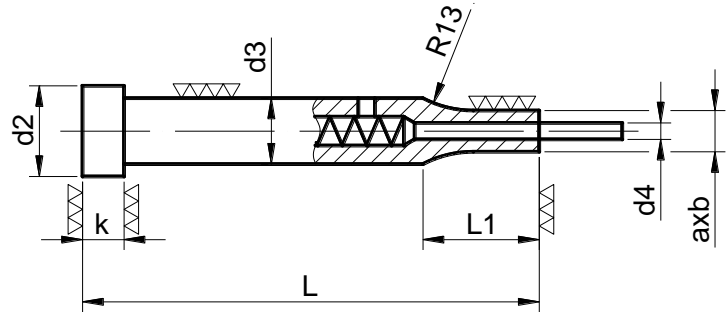

Material	Dureza	
	Vástago	Cabeza
HWS (12% Cr)	62±2 HRC	50±5 HRC
HSS	64±2 HRC	50±5 HRC

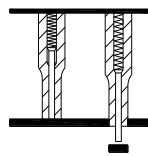

Tipo EKF

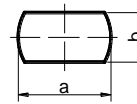

Tipo EKR

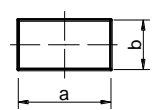

Tipo EKP

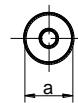

Tipo EKO

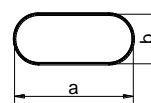

Tipo EKS

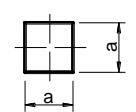

Tipo EKP	Tipo EKF		Tipo EKO		Tipo EKR		Tipo EKS	d2	d3	d4	k	L1	L ± 0,2		
a h6	a ± 0,02	b ± 0,02	a ± 0,02	b ± 0,02	a ± 0,02	b ± 0,02	a ± 0,02	⁰ _{-0,3}	m6	h6	^{+0,1} ₀	±0,5	63	72	80
3,5 - 6,0	3,0 - 6,0	2,5 - 5,5	3,0 - 6,0	2,5 - 5,5	2,5 - 3,0	2,5 - 3,0	2,5 - 4,0	9,0	6,0	1,2	3,0	13,0			
3,5 - 8,0	3,5 - 8,0	3,0 - 7,5	3,5 - 8,0	3,0 - 7,5	3,0 - 6,0	3,0 - 4,0	3,0 - 5,5	11,0	8,0	1,2	3,0	14,0			
4,5 - 10,0	5,0 - 10,0	4,5 - 9,5	5,0 - 10,0	4,5 - 9,5	4,5 - 7,0	4,5 - 6,0	4,5 - 7,0	13,0	10,0	1,6	5,0	16,0			
6,0 - 13,0	6,5 - 13,0	6,0 - 12,5	6,5 - 13,0	6,0 - 12,5	6,0 - 9,5	6,0 - 8,0	6,0 - 9,0	16,0	13,0	1,6	5,0	21,0			
9,0 - 16,0	9,5 - 16,0	9,0 - 15,5	9,5 - 16,0	9,0 - 15,5	7,0 - 12,5	7,0 - 9,0	7,0 - 11,0	19,0	16,0	2,0	6,0	24,0			
12,0 - 20,0	12,5 - 20,0	12,0 - 19,5	12,5 - 20,0	12,0 - 19,5	8,0 - 10,0	8,0 - 10,0	9,5 - 14,0	24,0	20,0	2,0	6,0	27,0			
17,0 - 25,0	17,5 - 25,0	17,0 - 24,5	17,5 - 25,0	17,0 - 24,5	10,0 - 21,0	10,0 - 12,0	12,5 - 17,5	31,0	25,0	2,0	10,0	32,0			